

TECHNICAL DATA

Model:	100 Series
Spec:	Dual Motor System
Max Load:	200 lbs
Design:	3-Stage Base
Height Control:	Digital Programmable
Height Range:	24" - 50"
Safety:	Anti-Collision TUV-Mark Certification
Electrical:	UL / ROHS Certified
Power Usage:	.1 w - stand by consumption

ELECTRIC HEIGHT  
SIT / STAND BASE

**MODEL 100/24**  
**MODEL 100/30**



Recommended Top Sizes:

24" Foot: Width: 24" - 30"

30" Foot: Width: 30" - 36"

Length: 48" - 84"

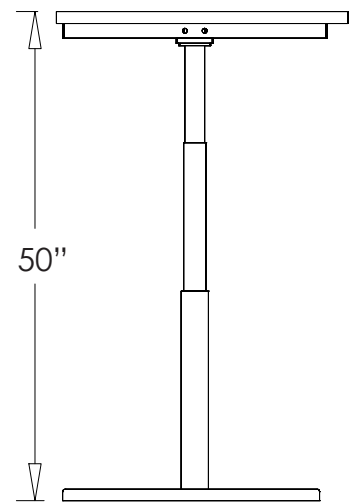
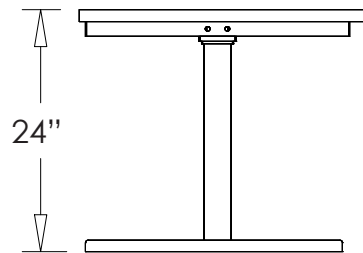
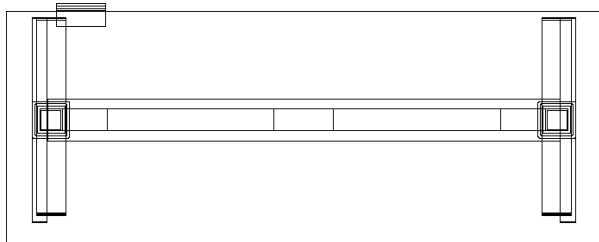

TECHNICAL DATA

Model:	100 Series
Spec:	Dual Motor System
Max Load:	200 lbs
Design:	3-Stage Base
Height Control:	Digital Programmable
Height Range:	24" - 50"
Safety:	Anti-Collision TUV-Mark Certification
Electrical:	UL / ROHS Certified
Power Usage:	.1 w - stand by consumption

ELECTRIC HEIGHT  
SIT / STAND BASE

MODEL 100/90-30  
MODEL 100/90-24



Recommended Top Sizes:  
24" Foot: Width: 24" - 30"  
30" Foot: Width: 30" - 36"  
Length: 48" - 84"

